

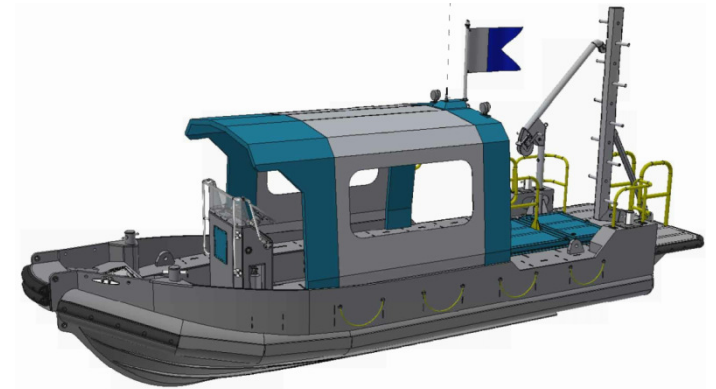

# 750/850-ID

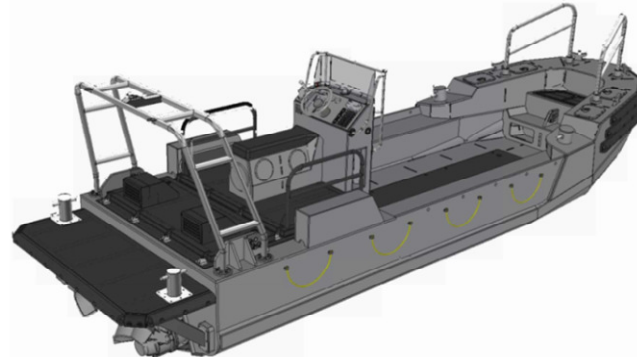
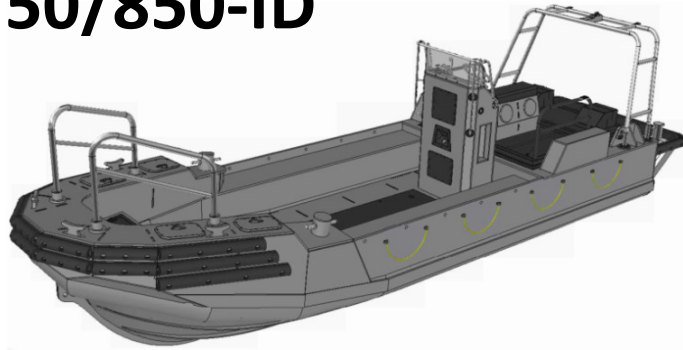

## ***RHINO 750/850 INBOARD OPTION***

The Rhino 750/850 boats can be supplied with Inboard Diesel Engine matched to a Water Jet or Stern Drive.

For inboard installations we recommend a single mechanically controlled Yanmar inboard diesel engine. For Jet Drive propulsion we would typically match to a MJJ or Hamilton Jet. The exact jet diameter and gear box (if required) will be matched based on speed and bollard pull requirements for the boat. For stern drive propulsion we would typically match to a Yanmar, Mercruiser or Volvo Penta stern drive system.

For twin inboard installations we recommend our wider beam SB hulls or the Broad Beam Deep-V Sponson Boats 950/1050 EHD-ID.

## ***RHINO 750/850 INBOARD SPECS***

- STERN INBOARD ENGINE & DRIVE COMPARTMENT;*
- ALUMINIUM FRAME ACCESS HATCHES TO ENGINE & DRIVE ;*
- VENTILATION & FIRE PROTECTION SYSTEM IN ENGINE COMPARTMENT;*
- WET EXHUAST SYSTEM;*
- INTEGRATED CONSOLE & COXSWAIN SEATING FWD OR AFT;*
- TOP MOUNT MECHANICAL INBOARD ENGINE CONTROLS;*
- JET/STERN DRIVE HYDRO-MECHANICAL STEERING & CONTROLS;*
- INBOARD FUEL SYSTEM WITH RETURN LINES & FILTERS;*

- \*OPTIONAL CANOPY, CABIN, SEATING ARRANGEMENTS & SRP DIVE EQUIPMENT*
- \*ELECTRICS & NAV/COM OPTIONS*

*REC INBOARD DIESEL ENGINE: YANMAR 4LHA-STP 240 HP*

*REC WATER JET DRIVE: HAMILTON HJ 241*

*REC STERN/Z-DRIVE: YANMAR, MERCUISER, VOLVO PENTA*