



Rhino Marine Products (Pty) Ltd

41 Manhattan Street, Airport Industria 7490
P.O. Box 173, Cape Town International Airport, 7525
Company Registration - 2005/012752/07
Vat Registration – 4500221421
Factory: +27 (0) 21-380-0068
Sales: +27 (72) 999-4114
Accounts: +27 (82) 325-3119
www.rhinomarineboats.com



RHINO CRAFT HDPE DEEP-V SPONSON 600-750-850 HD & EHD



Our traditional Rhino Craft were developed to incorporate rigid pipe sponsons which are foam-filled and which act as the chine between the bulwark and the hull. These pipe sponsons are the most likely section of the craft to be impacted on by semi submerged obstructions and are monolithically constructed into the hull and deck plates, the lateral frames, and the bulwark giving an enormously strong hull structure. For almost two decades the our original Rhino Sponson boats have been successfully operating in the off-shore oil and gas industry and are still going strong.

The narrow beam Rhino Sponson boats have been designed with the maximum allowable beam for shipping in standard width 20ft or 40ft containers, and are available in 6m (600), 7.5m (750), 8.5m (850) lengths. In each length the boats are available in HD (heavy duty) or EHD (extra heavy duty) versions. The HD and EHD version have the same hull design, but the EHD has more robust forepeak structure with additional fenders and bow transfer hand rails. This forepeak structure has been designed to operate with surfer type off-shore bow catchers and also results in a robust & high impact resistant bow section. Although the HD version is compatible with bow catchers we recommend the EHD version for frequent operation in that capacity.

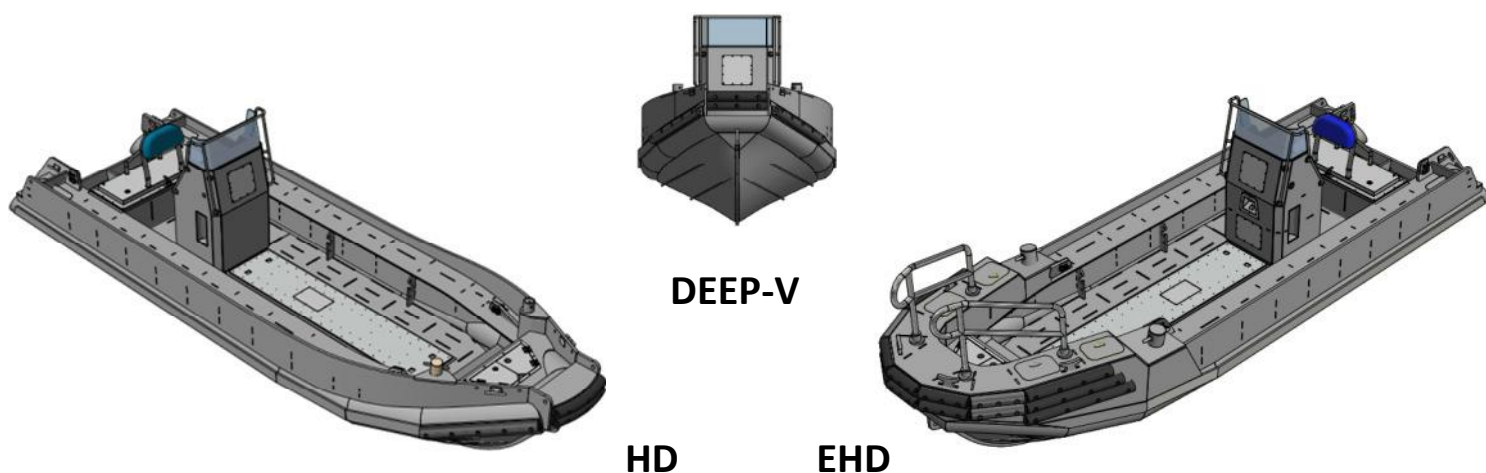

The EHD/HD sponson boats with extremely robust design attributes remain popular in the off shore oil and gas industry as general purpose work boats, tenders, daughter craft, etc. The 600 can be supplied with jockey seat & console arrangement or open deck for use with tiller operated outboard engines. Our preferred four stroke outboard engines are Yamaha, but we can also supply and install Mercury & Suzuki engines. For the off-shore oil and gas industry we offer the 600 boats with Yanmar D40/D36 Outboard Diesel Engines in tiller or RC control. The 750/850 boats can also be supplied with Yanmar D40/D36 Outboard Diesel Engines or OXE Diesel Outboard Engines for higher HP. Inboard diesel engine & jet/stern drive installations are available for 750/850 boats. The deep V hull design with sponsons also allows for high speed manoeuvrability and the 750/850 have proven to be well suited for fast patrol craft, FRC and MPB application. The 750/850 boats are also suited for general work boats, SRP dive boats, survey vessels and cargo/passenger transfer.



Our standard console versions are supplied with HDPE console which can be positioned FWD, AFT or mid ships. T-Top Canopy, Aluminium Frame Canopy, Enclosed Cabin and additional Seating Arrangements are available. The sponson boats can be supplied with electrical systems, hydraulic steering and nav/coms systems.



Rhino Marine Products
DEEP-V SPONSON RANGE



600 HD

600 EHD

750 HD

750 EHD

850 HD

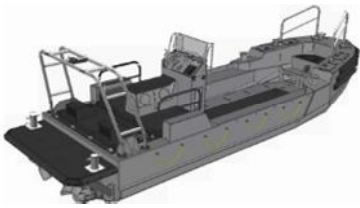
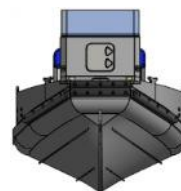
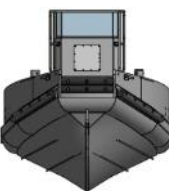
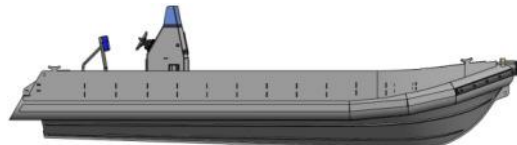
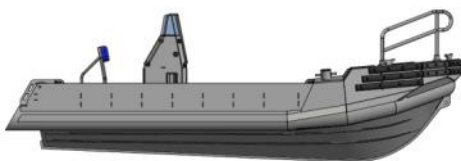
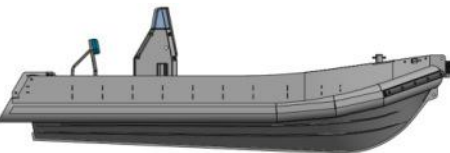
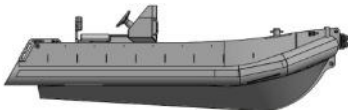
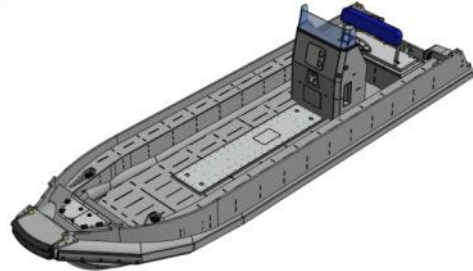
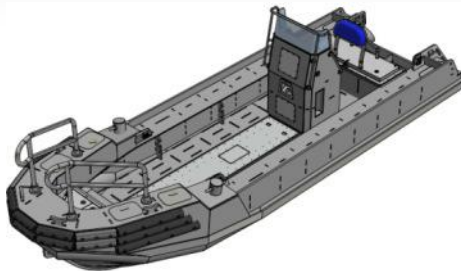
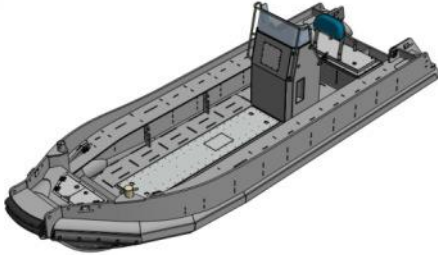
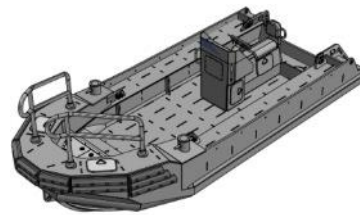
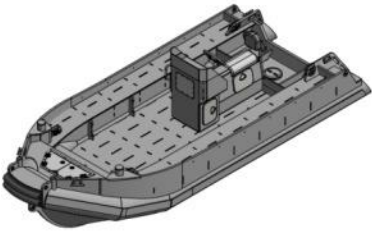

600 TILLER OPTION

750/850 INBOARD OPTIONS

CANOPY & SEATING OPTIONS



Rhino Marine Products



600-HD

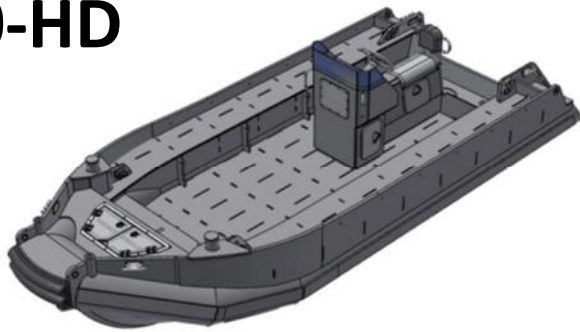

TILLER



CONSOLE



RHINO 600 HD SPECIFICATIONS

CLASS/CATEGORY: WORKBOAT-TENDER
MATERIAL: HDPE
ISO CATEGORY: C
PROPULSION: SINGLE/TWIN OUTBOARD L/UL SHAFT LENGTH
CONTROL: TILLER OR RC CONSOLE FWD/AFT
MAX REC POWER: 150 HP
MAX REC SPEED: 30 KNOTS
FUEL: GASOLINE/DIESEL-STANDARD ON DECK 25L TANKS
LENGTH OVERALL: 5.89 m
BREADTH: 2.28m
DEPTH HANDRAIL TO FOREPEAK: 2.05 m
LIGHT DRAFT: 0.25 m
DRY WEIGHT: 1990 KG
RECOMMENDED MAX PAYLOAD:1375 KG
MAX PERSONNEL: 5 (1 COXSWAIN & 4 CREW)
 ** Yanmar D36/D40 Diesel Outboard Engine supply & installation available.

RHINO 600 HD BOAT STRUCTURE

COMPLETE HDPE CONSTRUCTION RHINO 600 HD DEEP V HULL;
TILLER OPTION: 2 X STERN HDPE OPERATOR SEATS;
CONSOLE OPTION: HDPE CONSOLE & JOCKEY SEAT ARRANGEMENT;
PONTOON SEATING & UPSTANDS;
TOWING PAD EYE WITH SS BOSS;
RUBBING STRAKE ALONG PONTOONS;
HEAVY DUTY BOW D-FENDERS;
HEAVY DUTY BOLLARDS FWD;
BOW STORAGE/ANCHOR COMPARTMENT WITH ALU HATCHES;
VARIOUS CLEATS AND CONNECTING POINTS;
FOUR POINT REINFORCED LIFTING PAD-EYES;
WEBBED LIFTING SLINGS WITH SHACKLES & MASTER LINK;
NON SLIP SAND BLASTED DECK & WORK-SAFE RUBBER DECK MATT;
DUCTING, SCUPPER FLAPS & BUNGS.
 *BOW TRANSFER HANDRAILS ON REQUEST
 *T-TOP CANOPY, ALU FRAME CANOPY & SEATING OPTIONS
 *ELECTRICS, STEERING & NAV/COM OPTIONS



Rhino Marine Products



CONSOLE



TILLER

600-EHD

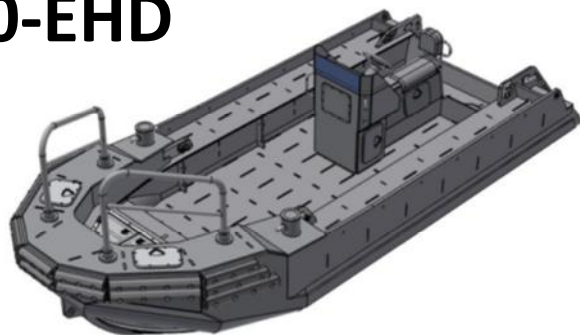

RHINO 600 EHD SPECIFICATIONS

CLASS/CATEGORY: WORKBOAT-TENDER
 MATERIAL: HDPE
 ISO CATEGORY: C
 PROPULSION: SINGLE/TWIN OUTBOARD L/UL SHAFT LENGTH
 CONTROL: TILLER OR RC CONSOLE FWD/AFT
 MAX REC POWER: 150 HP
 MAX REC SPEED: 40 KNOTS / 75 KM/H
 FUEL: GASOLINE/DIESEL-STANDARD ON DECK 25L TANKS
 LENGTH OVERALL: 5.89 m
 BREADTH: 2.28m
 DEPTH HANDRAIL TO KEEL: 2.24 m
 LIGHT DRAFT: 0.25 m
 DRY WEIGHT: 1230 KG
 RECOMMENDED MAX PAYLOAD: 2075 KG
 MAX PERSONNEL: 5 (1 COXSWAIN & 4 CREW)

** Yanmar D36/D40 Diesel Outboard Engine supply & installation available.

RHINO 600 EHD BOAT STRUCTURE

COMPLETE HDPE CONSTRUCTION RHINO 600 EHD DEEP V HULL;
 *ROBUST FOREPEAK STRUCTURE WITH ALU BOW TRANSFER HAND RAILS;
 *EXTRA HEAVY DUTY BOW D-FENDER ARRANGEMENT;
 TILLER OPTION: 2 X STERN HDPE OPERATOR SEATS;
 CONSOLE OPTION: HDPE CONSOLE & JOCKEY SEAT ARRANGEMENT;
 PONTOON SEATING & UPSTANDS;
 TOWING PAD EYE WITH SS BOSS;
 RUBBING STRAKE ALONG PONTOONS;
 HEAVY DUTY BOLLARDS FWD;
 BOW STORAGE/ANCHOR COMPARTMENT WITH ALU HATCHES;
 VARIOUS CLEATS AND CONNECTING POINTS;
 FOUR POINT REINFORCED LIFTING PAD-EYES;
 WEBBED LIFTING SLINGS WITH SHACKLES & MASTER LINK;
 NON SLIP SAND BLASTED DECK & WORK-SAFE RUBBER DECK MATT;
 DUCTING, SCUPPER FLAPS & BUNGS;
 *T-TOP CANOPY, ALU FRAME CANOPY & SEATING OPTIONS
 *ELECTRICS, STEERING & NAV/COM OPTIONS



Rhino Marine Products



750-HD

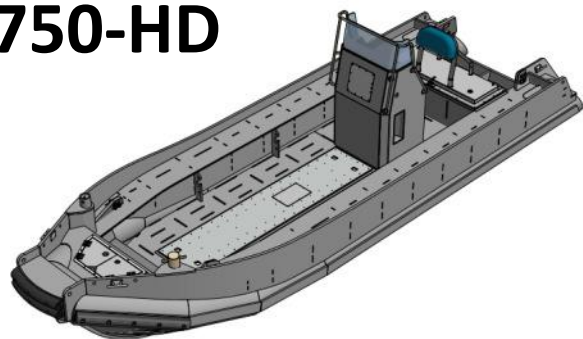

RHINO 750 HD SPECIFICATIONS

CLASS/CATEGORY: WORKBOAT-TENDER-PATROL-SURVEY-FRC-DIVING-PASSENGER

MATERIAL: HDPE

ISO CATEGORY: C

PROPULSION: SINGLE/TWIN OUTBOARD L/UL SHAFT LENGTH

CONTROL: CONSOLE RC FWD/AFT

MAX REC POWER: 400 HP

MAX REC SPEED: 45 KNOTS / 75 KM/H

FUEL: BUILT IN 260 L ALU FUEL TANK WITH FILTERS, FUEL LINE & FILLING STATION

LENGTH OVERALL: 7.57 m

BREADTH: 2.29m

DEPTH HANDRAIL TO KEEL: 2.47 m

LIGHT DRAFT: 0.35 m

DRY WEIGHT: 2050 KG

RECOMMENDED MAX PAYLOAD: 2290 KG

MAX PERSONNEL: 9 (1 COXSWAIN & 8 CREW)

*** YANMAR D36/D40 & OXE DIESEL Outboard Engine supply & installation available.*

RHINO 750 HD BOAT STRUCTURE

COMPLETE HDPE CONSTRUCTION RHINO 750 HD DEEP V HULL;

HDPE CONSOLE & UPHOLSTERED ALU COXSWAIN LEAN POST;

PONTOON SEATING & UPSTANDS;

TOWING PAD EYE WITH SS BOSS;

RUBBING STRAKE ALONG PONTOONS;

HEAVY DUTY BOW D-FENDERS;

HEAVY DUTY BOLLARDS FWD;

BOW STORAGE/ANCHOR COMPARTMENT WITH ALU HATCH;

STERN STORAGE COMPARTMENT WITH ALU HATCH;

VARIOUS CLEATS AND CONNECTING POINTS

FOUR POINT REINFORCED LIFTING PAD-EYES;

WEBBED LIFTING SLINGS WITH SHACKLES & MASTER LINK;

NON SLIP SAND BLASTED DECK & WORK-SAFE RUBBER DECK MATT

DUCTING, SCUPPER FLAPS & BUNGS.

** T-TOP CANOPY, ALU FRAME PORTAL CANOPY & ALU CABIN OPTIONS*

** ALU STERN ARCH, ENGINE PROTECTION FRAME & SEATING OPTIONS*

**ELECTRICS, STEERING & NAV/COM OPTIONS*



Rhino Marine Products



750-EHD

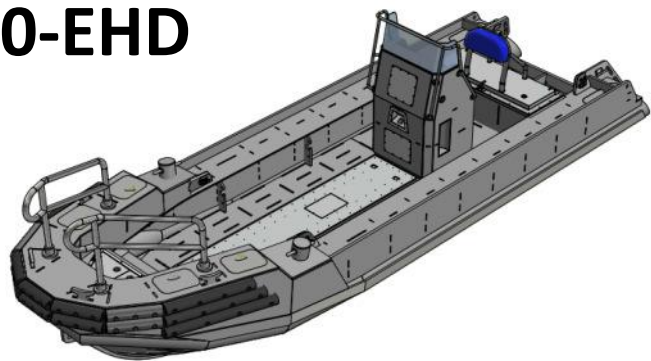

RHINO 750 EHD SPECIFICATIONS

CLASS/CATEGORY: WORKBOAT-TENDER-PATROL-SURVEY-FRC-DIVING-PASSENGER
MATERIAL: HDPE
ISO CATEGORY: C
PROPULSION: SINGLE/TWIN OUTBOARD L/UL SHAFT LENGTH
CONTROL: CONSOLE RC FWD/AFT
MAX REC POWER: 400 HP
MAX REC SPEED: 45 KNOTS / 75 KM/H
FUEL: BUILT IN 260 L ALU FUEL TANK WITH FILTERS, FUEL LINE & FILLING STATION
LENGTH OVERALL: 7.57 m
BREADTH: 2.29m
DEPTH HANDRAIL TO KEEL: 2.47 m
LIGHT DRAFT: 0.35 m
DRY WEIGHT: 2050 KG
RECOMMENDED MAX PAYLOAD: 2290 KG
MAX PERSONNEL: 9 (1 COXSWAIN & 8 CREW)
*** YANMAR D36/D40 & OXE DIESEL Outboard Engine supply & installation available.*

RHINO 750 EHD BOAT STRUCTURE

COMPLETE HDPE CONSTRUCTION RHINO 750 HD DEEP V HULL;
**ROBUST FOREPEAK STRUCTURE WITH ALU BOW TRANSFER HAND RAILS;*
**EXTRA HEAVY DUTY BOW D-FENDER ARRANGEMENT;*
HDPE CONSOLE & UPHOLSTERED ALU COXSWAIN LEAN POST;
PONTOON SEATING & UPSTANDS;
TOWING PAD EYE WITH SS BOSS;
RUBBING STRAKE ALONG PONTOONS;
HEAVY DUTY BOLLARDS FWD;
BOW STORAGE/ANCHOR COMPARTMENT WITH ALU HATCH;
STERN STORAGE COMPARTMENT WITH ALU HATCH;
VARIOUS CLEATS AND CONNECTING POINTS
FOUR POINT REINFORCED LIFTING PAD-EYES;
WEBBED LIFTING SLINGS WITH SHACKLES & MASTER LINK;
NON SLIP SAND BLASTED DECK & WORK-SAFE RUBBER DECK MATT
DUCTING, SCUPPER FLAPS & BUNGS.
** T-TOP CANOPY, ALU FRAME CANOPY, ALU CABIN & SEATING OPTIONS*
** STERN ARCH, ENGINE PROTECTION FRAME, STEERING, ELECTRICS & NAV/COM*



750/850-ID

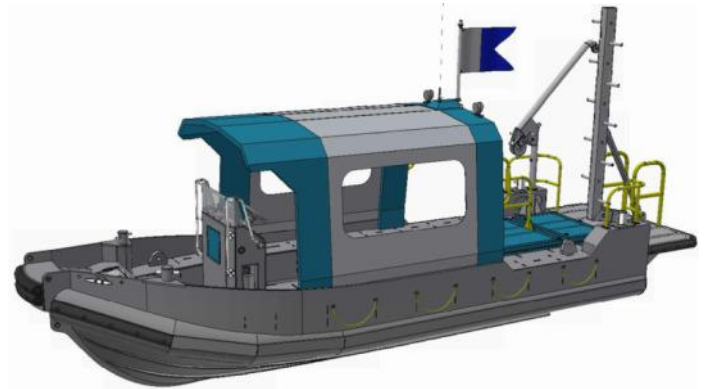
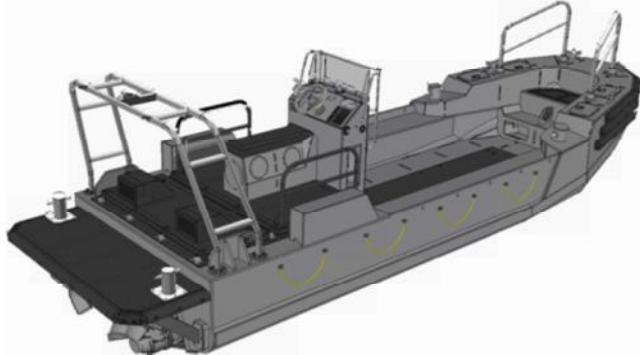
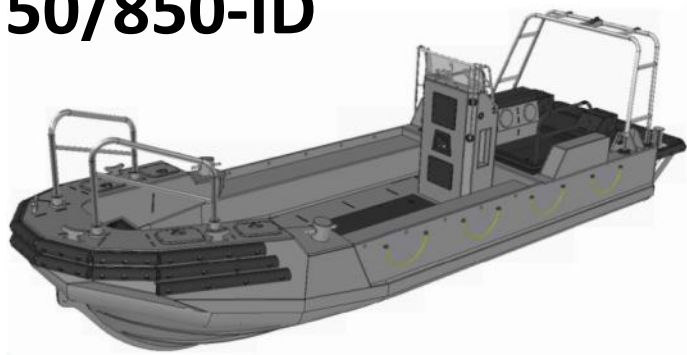

RHINO 750/850 INBOARD OPTION

The Rhino 750/850 boats can be supplied with Inboard Diesel Engine matched to a Water Jet or Stern Drive.

For inboard installations we recommend a single mechanically controlled Yanmar inboard diesel engine. For Jet Drive propulsion we would typically match to a MJP or Hamilton Jet. The exact jet diameter and gear box (if required) will be matched based on speed and bollard pull requirements for the boat. For stern drive propulsion we would typically match to a Yanmar, Mercruiser or Volvo Penta stern drive system.

For twin inboard installations we recommend our wider beam SB hulls or the Broad Beam Deep-V Sponson Boats 950/1050 EHD-ID.

RHINO 750/850 INBOARD SPECS

- STERN INBOARD ENGINE & DRIVE COMPARTMENT;*
- ALUMINIUM FRAME ACCESS HATCHES TO ENGINE & DRIVE ;*
- VENTILATION & FIRE PROTECTION SYSTEM IN ENGINE COMPARTMENT;*
- WET EXHUAST SYSTEM;*
- INTEGRATED CONSOLE & COXSWAIN SEATING FWD OR AFT;*
- TOP MOUNT MECHANICAL INBOARD ENGINE CONTROLS;*
- JET/STERN DRIVE HYDRO-MECHANICAL STEERING & CONTROLS;*
- INBOARD FUEL SYSTEM WITH RETURN LINES & FILTERS;*

- *OPTIONAL CANOPY, CABIN, SEATING ARRANGEMENTS & SRP DIVE EQUIPMENT*
- *ELECTRICS & NAV/COM OPTIONS*

- REC INBOARD DIESEL ENGINE: YANMAR 4LHA-STP 240 HP*
- REC WATER JET DRIVE: HAMILTON HJ 241*
- REC STERN/Z-DRIVE: YANMAR, MERCUISER, VOLVO PENTA*



850-HD

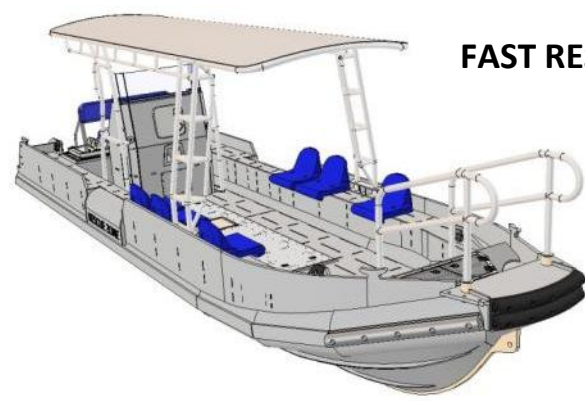
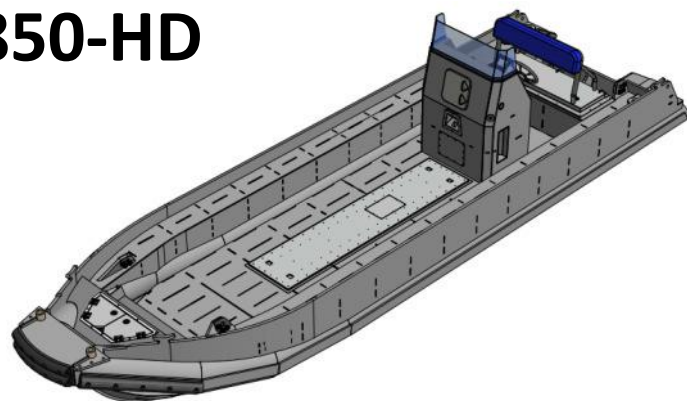

FAST RESCUE/PATROL BOATS

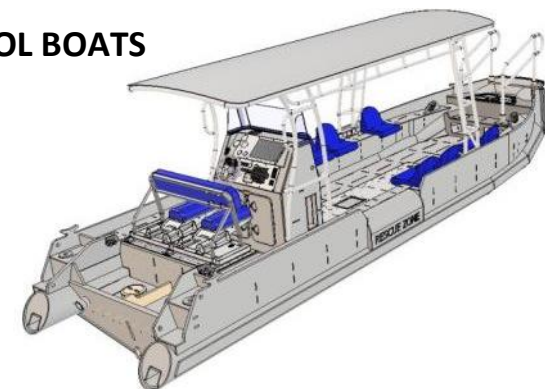

RHINO 850 HD SPECIFICATIONS

- CLASS/CATEGORY: WORKBOAT-TENDER-PATROL-SURVEY-FRC-DIVING-PASSENGER
- MATERIAL: HDPE
- ISO CATEGORY: C
- PROPULSION: SINGLE/TWIN OUTBOARD MAX REC POWER: 400 HP
- MAX REC SPEED: 45 KNOTS / 75 KM/H
- CONTROL: CONSOLE RC FWD/AFT
- FUEL: BUILT IN 260 L ALU FUEL TANK WITH FILTERS, FUEL LINE & FILLING STATION
- LENGTH OVERALL: 8.67 m
- BREADTH: 2.29m
- DEPTH HANDRAIL TO KEEL: 2.47 m
- LIGHT DRAFT: 0.35 m
- DRY WEIGHT: 2600 KG
- RECOMMENDED MAX PAYLOAD: 2350KG
- MAX PERSONNEL: 9 (1 COXSWAIN & 8 CREW)
- SHIPPING SPEC: IN GAUAGE 20 FT CONTAINER

*SPECIFICATIONS IN THIS DOCUMENT ARE CIRCUMSTANTIAL & SUBJECT TO CHANGE. DRY WEIGHT, PAYLOAD AND PERSONNEL CAPACITY WILL VARY DEPENDING ON PROPULSION, EQUIPMENT & SUPER STRUCTURE INSTALATIONS. BOAT PERFORMANCE WILL VARY IN DEFFERENT SEASTATE CONDITIONS.

RHINO 850 HD BOAT STRUCTURE

- COMPLETE HDPE CONSTRUCTION RHINO 750 HD DEEP V HULL;
- HDPE OR ALU CONSOLE & UPHOLSTERED ALU COXSWAIN LEAN POST;
- PONTOON SEATING & UPSTANDS;
- TOWING PAD EYE WITH SS BOSS;
- RUBBING STRAKE ALONG PONTOONS;
- HEAVY DUTY BOW D-FENDERS;
- HEAVY DUTY BOLLARDS FWD;
- BOW STORAGE/ANCHOR COMPARTMENT WITH ALU HATCH;
- STERN STORAGE COMPARTMENT WITH ALU HATCH;
- VARIOUS CLEATS AND CONNECTING POINTS
- FOUR POINT REINFORCED LIFTING PAD-EYES;
- WEBBED LIFTING SLINGS WITH SHACKLES & MASTER LINK;
- NON SLIP SAND BLASTED DECK & WORK-SAFE RUBBER DECK MATT
- DUCTING, SCUPPER FLAPS & BUNGS.
- * T-TOP CANOPY, ALU FRAME PORTAL CANOPY & ALU CABIN OPTIONS
- *ALU STERN ARCH, ENGINE PROTECTION FRAME & SEATING OPTIONS
- *RESCUE ZONE, JASON CRADLE, RESCUE DAVIT, ELECTRICS & NAV/COMS OPTIONS